

- 93 Cap
 93a Plate
 93b Locking pin

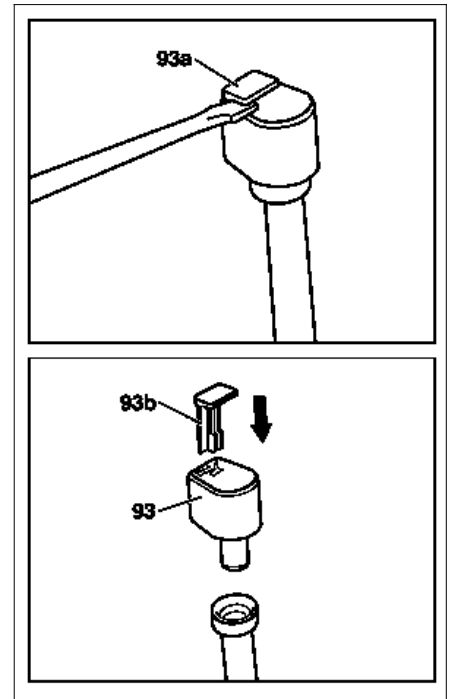

P27.00-2232-03

- 1 Oil cooling line connection
 2 Right oil cooling line
 3 Banjo bolt

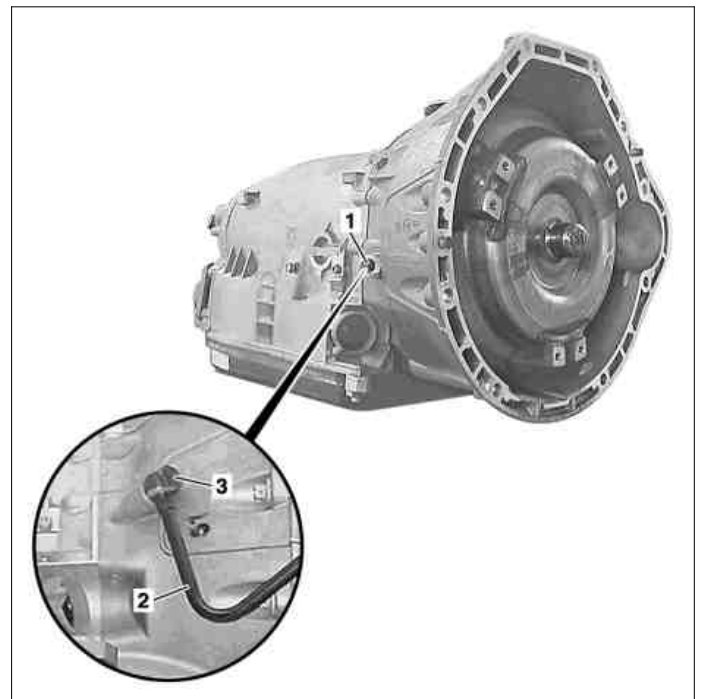

P27.55-2047-12

- 1 Oil cooling line connection
- 2 Right oil cooling line
- 3 Banjo bolt
- 4 Connector
- 5 Hose clamp

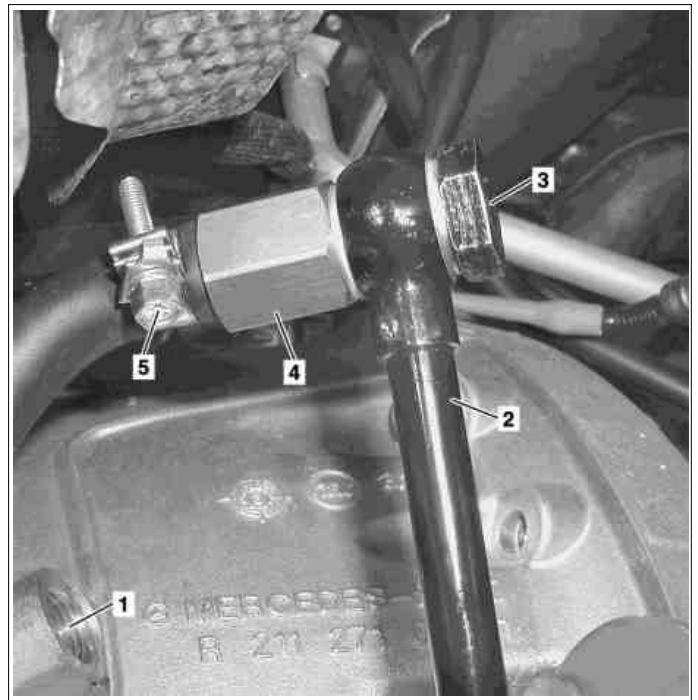

P27.55-2048-12

	Remove/install		
Danger!	Risk of injury to skin or eyes caused by hydraulic fluid spraying out under high pressure. Risk of poisoning caused by swallowing hydraulic fluid	Depressurize the hydraulic system completely before starting any work on the system. Wear protective clothing and safety glasses.	AS00.00-Z-0013-01A
Danger!	Risk of accident caused by vehicle starting off by itself when engine is running. Risk of injury caused by contusions and burns during starting procedure or when working near the engine as it is running	Secure vehicle to prevent it from moving by itself. Wear closed and snug-fitting work clothes. Do not touch hot or rotating parts.	AS00.00-Z-0005-01A
Danger!	Risk of death caused by vehicle slipping or toppling off of the lifting platform.	Align vehicle between columns of vehicle lift and position four support plates at vehicle lift support points specified by vehicle manufacturer.	AS00.00-Z-0010-01A
	Notes on self-locking nuts and bolts		AH00.00-N-0001-01A
	Before opening the hydraulic system, thoroughly clean the area surrounding the separation point. Even the smallest dirt particles, introduced into the hydraulic components, can lead to malfunctions and a total failure of the hydraulic system		
1.1	Remove the rear section of the engine compartment paneling	Vehicles with gasoline engine except model 461 and 463 Model 129, 202, 208, 210 Model 140 Model 163 except 163.136/154/157 Model 163.136/154/157 Model 170 Model 171 Model 199 Model 209, 203 with gasoline engine Model 211 Model 219 Model 215, 220 Model 230 Model 240	AR61.20-P-1105AB AR61.20-P-1105GH AR61.20-P-1105A AR61.20-P-1105V AR61.20-P-1105SLR AR61.20-P-1105P AR61.20-P-1105T AR61.20-P-1105TX AR61.20-P-1105M AR61.20-P-1105R AR61.20-P-1105H
1.2	Remove rear part of bottom sections of soundproofing	Vehicles with diesel engine except model 461 and 463 Model 140 Model 163 Model 202.1 Model 209, 203 with diesel engine Model 210 Model 211 Model 220	AR94.30-P-5400GH AR94.30-P-5300A AR94.30-P-5300P AR94.30-P-5300AB AR94.30-P-5300T AR94.30-P-5300M

2	Remove drain plug from the transmission oil pan and drain transmission oil	The transmission oil should have an operating temperature of 80 °C. 	*BA27.10-P-1001-03A
3	Detach transmission oil pan and install a new transmission oil filter	Caution: when removing the transmission oil pan, approx. 2.5 liters of transmission oil will still be in the transmission oil pan.	
4	Mount transmission oil pan	Install new gasket. 	*BA27.10-P-1002-03A
5	Detach clamps for right oil cooling line (2) from engine oil pan	Model 163, 171, 211, 219, 220, 461, 463 Model 199, 203, 209, 215, 230	*BA27.55-P-1008-01B *BA27.55-P-1003-01B
6	Remove banjo bolt (3) from connection (1) on right oil cooling line (2)	Model 163, 171, 211, 219, 220, 461, 463 Model 199, 203, 209, 215, 230	*BA27.55-P-1002-01B *BA27.55-P-1002-01B
7	Join connection fitting (4) with an approx. 1.5 meter long hose using a hose clamp (5)	Remove the connection fitting (4) from the hand pump. 	*210589007100
8	Mount banjo bolt (3) and oil cooling line (2) to connection fitting (4)		
9	Hold hose into a bucket with a scale on it	The bucket should have a capacity of 10 liters.	
10	Unlock cap (93)	Break off plate (93a) using a suitable tool and press out locking pin (93b) remaining in cap (93) downwards.	
11	Detach cap (93) from oil filler pipe		
12	Mount funnel onto oil filler pipe and fill transmission with 5 liters of oil	The entire flushing procedure requires 14 liters of transmission oil. 	*126589126300
	Flushing		
	An assistant is required for the flushing procedure		
13	Start the engine and drain transmission oil via the hose into the bucket	Always observe work procedure and Specifications for Operating Fluids, otherwise transmission will be damaged.	
14	Once 3 liters of transmission oil are in the bucket stop the engine immediately		
15	Pour in 3 liters of transmission oil		
16	Repeat flushing procedure twice		
17	Check oil level in automatic transmission, correct if necessary		AR27.00-P-0100AC
18	Install in the reverse order		
19	Carry out engine test run, checking the transmission for function and oil leaks		

Oil pan, automatic transmission

Number	Designation		Trans- mission 722.6 except 722.628/ 648/649	Trans- mission 722.628	Trans- mission 722.648	Trans- mission 722.649
BA27.10-P-1001-03A	Oil drain screw to oil pan	Nm	20	20	20	22
BA27.10-P-1002-03A	Bolt, oil pan to transmission housing	Nm	8	8	8	8
		°	-	-	-	-

Transmission oil cooling

Number	Designation			Transmission 722.6 in model 163	Transmission 722.6 in model 199	Transmission 722.6 in model 170, 171, 203, 209, 210, 215, 219, 220, 230, 240
BA27.55-P-1002-01B	Banjo bolt or union nut, oil cooler line to torque converter and transmission housing	Stage 1	Nm	20	20	5
		Stage 2	∠°	-	-	90
		Hexalobular bolt	Nm	-	-	-
BA27.55-P-1003-01B	Bolt, oil cooler line to engine oil pan		Nm	11	-	11
BA27.55-P-1008-01B	Bolt, oil cooler line retaining clamp to oil pan		Nm	8	-	8

Transmission oil cooling

Number	Designation			Transmission 722.6 in model 204, 216, 221	Transmission 722.6 in model 211	Transmission 722.6 in model 461, 463
BA27.55-P-1002-01B	Banjo bolt or union nut, oil cooler line to torque converter and transmission housing	Stage 1	Nm	5	5	20
		Stage 2	∠°	90	90	-
		Hexalobular bolt	Nm	12	-	-
BA27.55-P-1003-01B	Bolt, oil cooler line to engine oil pan		Nm	11	11	-
BA27.55-P-1008-01B	Bolt, oil cooler line retaining clamp to oil pan		Nm	-	8	8

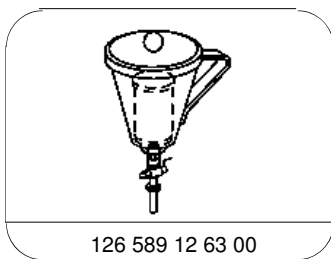

Funnel

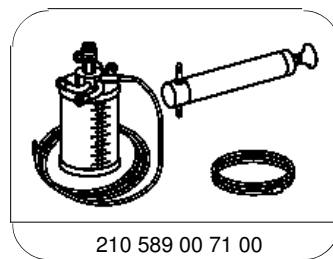

Hand pump