

- 1 Raste (Pfeil) hineindrücken.
- 2 Schalthebel zur Fixierung der Grundposition in Querrichtung bewegen.

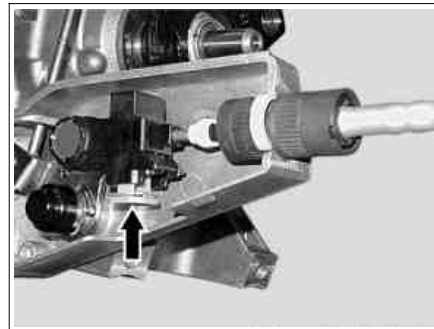

P26.60-2039-01



Darauf achten, dass die Schenkelfeder (3) am Lagerbock (Pfeile) anliegt.

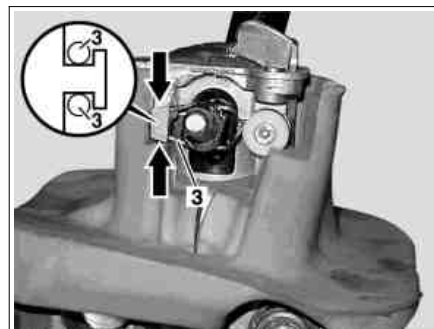

P26.60-2040-01

- 3 Auslösetaste (Pfeil) drücken.

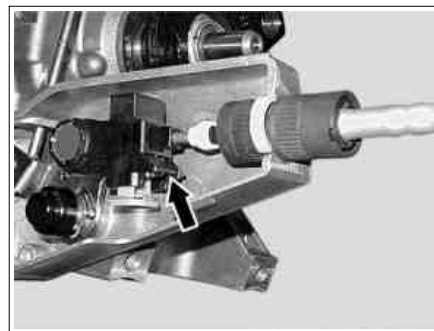

P26.60-2042-01