

MODELS 203 (except 203.081 /084 /087 /092 /281 /284 /287 /292)

MODELS 209.3/ 4

05a Extraction drift

9a Radial seal ring

9c Tapered roller bearing outer race of outer tapered roller bearing

9l Inner tapered roller bearing

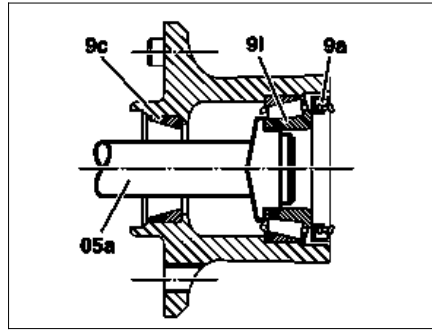

P33.00-0021-01

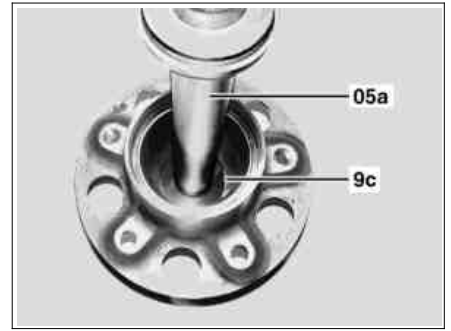

P33.00-2035-01

06b Insertion tool, part 02

06c Insertion tool, part 03

06d Insertion tool, part 10

9b Tapered roller bearing outer race of inner tapered roller bearing

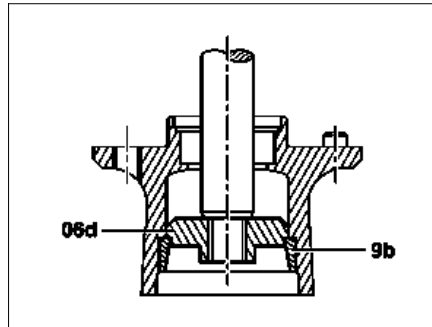

P33.00-2033-01

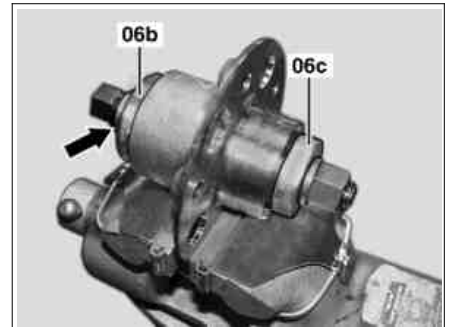

P33.00-2034-01

06a Insertion tool, part 01

06b Insertion tool, part 02

9a Radial seal ring

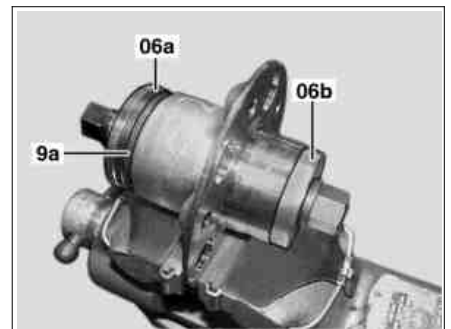

P33.00-2036-01

Modification notes

8.6.05	Filling capacity, hub (total filling quantity)	Models 203, 209	*BF33.20-P-1001-01A
--------	--	-----------------	---------------------

	Disassemble		
<b>Danger!</b>	<b>Risk of death</b> caused by vehicle slipping or toppling off of the lifting platform.	Align vehicle between the columns of the lifting platform and position the four support plates at the lifting platform support points specified by the vehicle manufacturer.	AS00.00-Z-0010-01A
1	Remove front wheel hub		AR33.20-P-0310P
2	Drive out inside tapered roller bearing (9l) and radial sealing ring (9a).	<p><b>i</b> The pulse ring of the rpm sensor is integrated in the radial sealing ring (9a), therefore this should always be replaced.</p> <p><b>i</b> Use drift (05a) to hammer out inner tapered roller bearing (9l) and radial sealing ring (9a).</p> <p> Drift punch</p>	*202589001500
3	Press out tapered roller bearing outer race of outer tapered roller bearing (9c)	<p><b>i</b> Use workshop press and drift (05a) to press out the tapered roller bearing outer race of outer tapered roller bearing (9c).</p> <p> Drift punch</p>	*202589001500
4	Press out tapered roller bearing outer race of inner tapered roller bearing (9b)	<p><b>i</b> Press out the tapered roller bearing outer race of the inner tapered roller bearing (9b) using insertion tool, part 10 (06d) and suitable drift.</p> <p> Insertion tool</p>	*203589024300

5	Clean tapered roller bearing and front wheel hub		
	<b>Check</b>		
6	Inspect tapered roller bearing and bearing races		AR33.20-P-0310-02P
7	Check front wheel hub	Check threaded sockets for damage.	
	<b>Assemble</b>		
8	Pull the tapered roller bearing outer race of the inner tapered roller bearing (9b) and the tapered roller bearing outer race of the outer tapered roller bearing (9c) into the front wheel hub	Pull the tapered roller bearing outer race of the inner tapered roller bearing (9b) and tapered roller bearing outer race of the outer tapered roller bearing (9c) into the front wheel hub using insertion tool, part 02 (06b) and insertion tool, part 03 (06c). The grooves in the bronze friction ring serve as the running contact surface and must be positioned opposite the second friction ring. Insertion tool	*203589024300
9	Insert inner tapered roller bearing (9l) into front wheel hub	Before inserting, grease the inner tapered roller bearing (9l).	
10	Pull in radial sealing ring (9a)	The exciter ring of the rpm sensor is integrated in the radial sealing ring (9a) and must not be processed using metallic tools. Therefore when pulling in, use the side of the insertion tool lined with rubber, part 01 (06a). Pull in the radial sealing ring (9a) up to the stop in the front wheel hub using insertion tool, part 01 (06a) and insertion tool, part 02 (06b). Coat and pack the contact surface of the radial sealing ring (9a) as well as the space between the lip and dust lip with grease. Insertion tool	*203589024300
11	Fill wheel hub with grease		*BF33.20-P-1001-01A

### Wheel hub, hub cap

Number	Designation	Models 203, 209
BF33.20-P-1001-01A	Filling capacity	
	Hub cover	g 15
	Hub (total capacity)	g 70
	Specifications for Operating Fluids	Sheet BB00.40-P-0265-01A

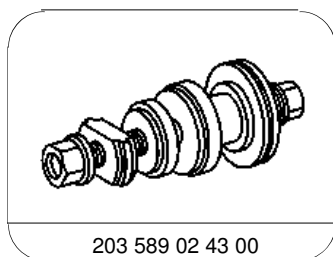

Insertion tool

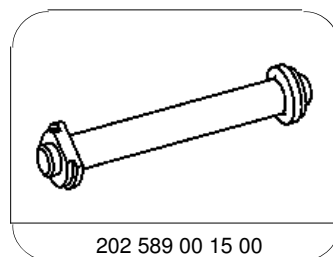

Extraction drift