

P88.20-2744-09

- 2 Clips
- 3 Bolt
- 9 Bolts

- 6 Nuts
- 8 Guide

- 10 Adjustment bolt

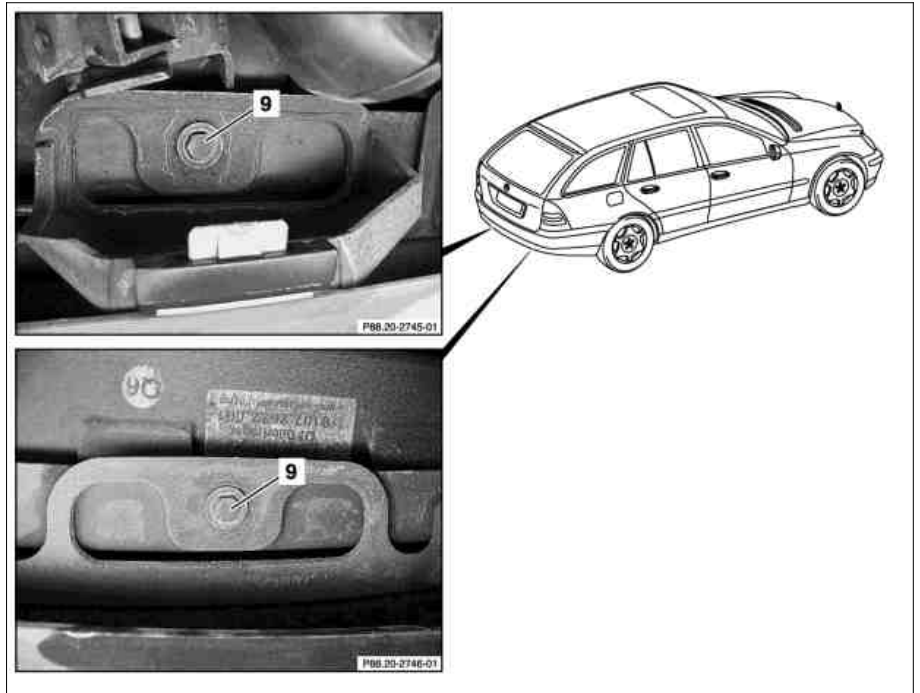

P88.20-2747-06

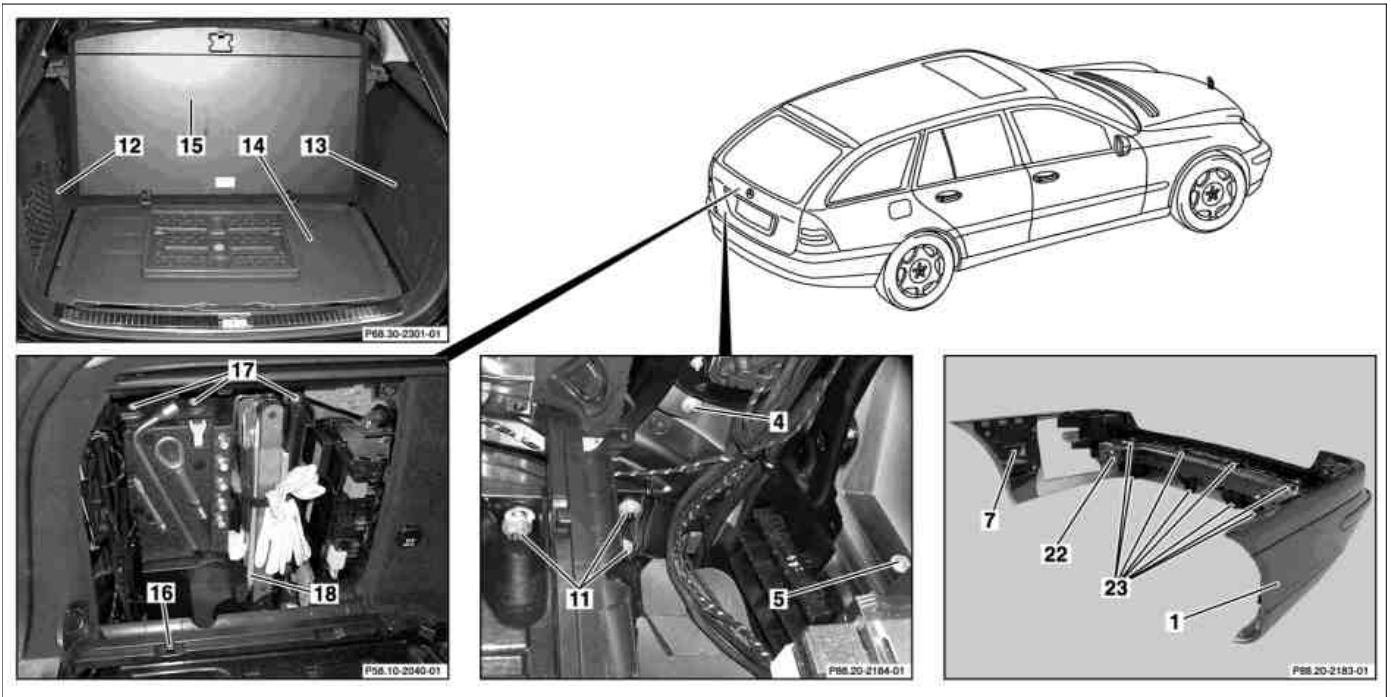

P88.20-2182-09

- | | | | | | |
|----|---------|----|-----------------------------------|----|-----------------|
| 1 | Bumper | 12 | Left paneling flap | 17 | Bolts |
| 4 | Nut | 13 | Right paneling flap | 18 | Tool holder |
| 5 | Bolt | 14 | Paneling below rear loading floor | 22 | Impact absorber |
| 7 | Bracket | 15 | Rear loading floor | 23 | Bolts |
| 11 | Nuts | 16 | Bolt | | |

	Remove		
1.1	Loosen nuts (6) on adjustment screw (10)	With trailer hitch, code 550	
2	Remove clips (2) from rear fender liners		
3	Loosen bolts (9) on rear bumper (1) at bottom		
4	Slacken bolts (3)		
5	Remove rear loading floor (15)		
6	Remove paneling below rear loading floor (14).		
7	Remove paneling flap on left (12) and right (13).	Actuate releases in load compartment.	
8.1	Remove bass box with amplifier	With sound system, code 810	AR82.62-P-7839PA
9	Remove tool holder (18)		
10.1	Disconnect PTS connector, rear bumper (X35/28)	With Parktronic system (PTS)	
11.1	Remove nuts (11)	Except trailer hitch, code 550	
12	Unscrew nuts (4) and bolts (5)		
13	Remove bumper (1)		
14.1	Remove impact absorber (22) from bumper (1)	Only when replacing bumper (1). Unscrew bolts (23)	
	Install		
15.1	Install impact absorber (22) on bumper (1)	Only if bumper (1) is replaced. For this, purpose tighten bolts (23).	
16	Install bumper (1)	When installing, ensure that brackets (7) are moved into guides (8) on left and right. With trailer hitch, code 550, install adjustment bolts (10) in guides (8)	
17	Tighten bolts (3)	Move bumper (1) until edge of bumper (1) is flush with edge of rear fender. Check gaps on bumper (1), correct if necessary, see: ↓ Gaps on hoods, doors and lids Model 203.2 except model 203.276 Model 203.276	AR60.00-P-0700-01PA AR60.00-P-0700-01AC
18	Tighten nuts (4) and bolts (5)	Screw with sealing washer for rear bumper on fender	*BA88.20-P-1005-01A

19.1	Tighten nuts (11)	With trailer hitch, code 550 Nm Nut for rear bumper on rear center section	*BA88.20-P-1002-01A
20.1	Position nuts (6).	With trailer hitch, code 550 i Position nuts (6) only until it is possible to turn the adjustment bolts (10)	
21.1	Adjust uniform gap on bumper (1) with adjustment bolts (10).	With trailer hitch, code 550	
22.1	Tighten nuts (6)	With trailer hitch, code 550	
23	Tighten bolts (9) on rear bumper (1) at bottom		
24	Press in clips (2)		
25.1	Clip in rear bumper PTS connector (X35/28)	With Parktronic system (PTS)	
26	Install tool holder (18)		
27.1	Install bass box with amplifier	With sound system, code 810	AR82.62-P-7839PA
28	Install paneling flaps on left (12) and right (13).		
29	Install paneling below rear loading floor (14)		
30	Install rear loading floor (15)		

Nm Bumper

Number	Designation		Model 203
BA88.20-P-1002-01A	Nut, rear bumper to rear center section	Nm	6
BA88.20-P-1005-01A	Bolt with sealing washer, rear bumper to side fender	Nm	8