

MODEL 209

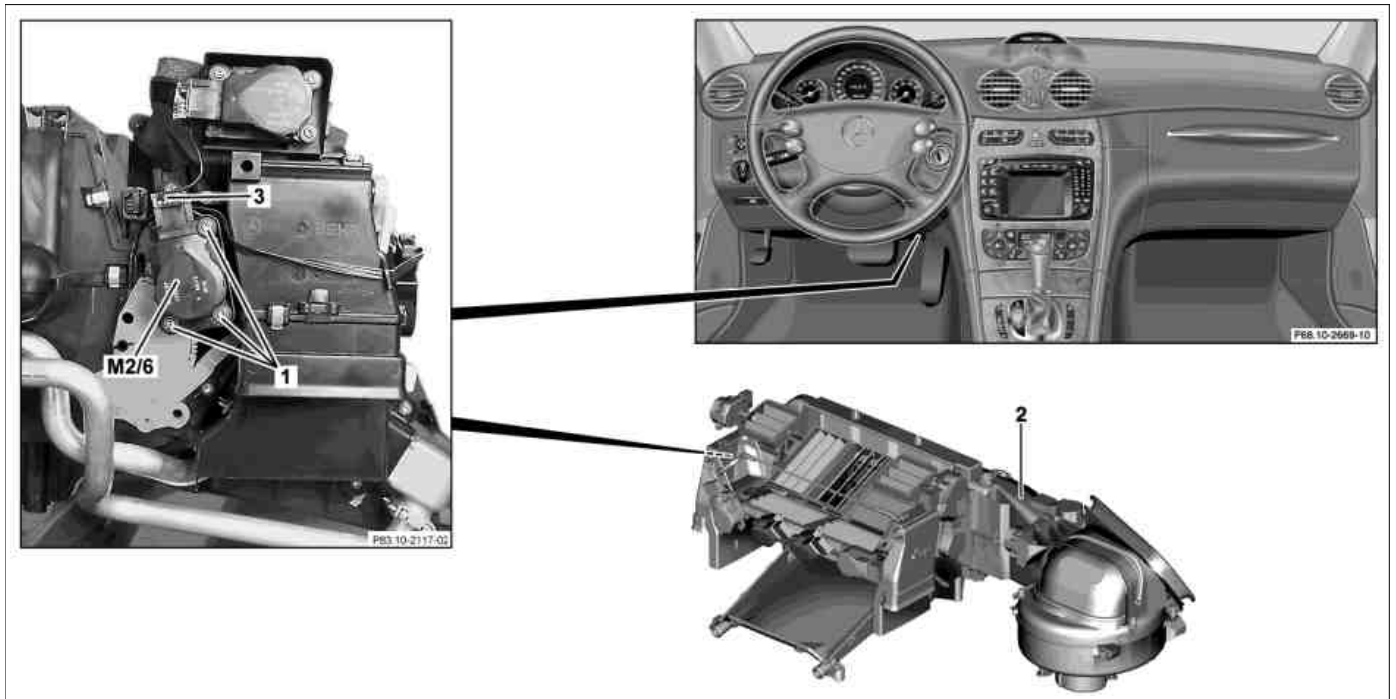

P83.10-2251-09

1 Bolts
2 AC housing

3 Electrical connector

M2/6 Left blended air flap positioning motor

Modification notes

18.2.04	Disconnect/connect/remove ground lead from battery		
---------	--	--	--

Remove/Install		
1	Remove cover below left of instrument panel	AR68.10-P-1500P
2	Remove bolts (1)	
3	Remove left blending air flap actuator motor (M2/6)	
4	Separate electrical connection (3)	
5	Install in the reverse order	
6	Connect STAR DIAGNOSIS, normalize left blending air flap actuator motor (M2/6), read out fault memory and delete Connect STAR DIAGNOSIS and read out fault memory	AD00.00-P-2000-04A *WH58.30-Z-1048-13A
7	Perform function check	

Commercially available tools

Number	Designation	
WH58.30-Z-1048-13A	STAR DIAGNOSIS diagnosis system, Compact Passenger Car	6511 1801 00