

Code:	Designation:	Position:
A0	Color code key	25L
A7/5	RVC [UVS] hydraulic unit	26L
A7/5b1	Temperature sensor	24L
A7/5k1	Relay	25L
A7/5m1	Motor	46L
A7/8	RTC [HDFS] hydraulic unit	44L
B24/16	Trunk lid position sensor	6L
K40/5	Rear fuse and relay module	22L
K40/5	Rear fuse and relay module	8L
K40/5f62	Fuse 62	9L
K40/5f63	Fuse 63	4L
K40/5f68	Fuse 68	5L
K40/5f69	Fuse 69	23L
K40/5f73	Fuse 73	21L
K40/5f74	Fuse 74	17L
M10/5	Left rear power window motor	13L
M10/6	Right rear power window motor	10L
M49/1	Side flaps motor	4A
N52	RSC [UVS] control unit	12A
N52	RSC [UVS] control unit	20A
N52	RSC [UVS] control unit	28A
N52	RSC [UVS] control unit	36A
N52	RSC [UVS] control unit	44A
N52	RSC [UVS] control unit	52A
N52	RSC [UVS] control unit	63A
N72	Lower control panel control unit	63L
N72e3	Vario roof indicator lamp	62L
S114	Load assist switch	31L
S117	Load assist up/down limit switch	28L
S117x1	Load assist up/down end switch connector	28J
S118/1	Left tubular frame "locked" limit switch	33L
S118/2	Right tubular frame "locked" limit switch	34L
S119	Tubular frame "open" limit switch	66L
S124	Trunk lid "open" limit switch	41L
S126/1	Left side flap "closed/open" limit switch	36L
S127/1	Right side flap "closed/open" limit switch	39L
S69/11	Vario roof "up/down" limit switch	27L
S69/11x1	Vario-roof "open/lowered" limit switch connector	26J

Document number: pe77.39-p-2101-97kb

Document title: Wiring diagram for Vario roof control module

Code:	Designation:	Position:
S69/2	Vario roof "locked" limit switch (right rotary tumbler)	67L
S69/3	Vario roof "locked" limit switch (left rotary tumbler)	68L
S83/10	Roll bar "down/up" limit switch	30L
U12	Valid for left-hand drive vehicles	57F
U127	Valid for engine 272, engine 273 KE	
U127	Valid for engine 272, engine 273 KE	
U13	Valid for right-hand drive vehicles	57F
U152	Valid for engine 156	
U152	Valid for engine 156	
U19	Valid for M112.973, M113.963	2G
U19	Valid for M112.973, M113.963	19G
U332	Valid for RTC [HDFS]	42F
U425	Valid for SL 55 AMG	2H
U425	Valid for SL 55 AMG	19H
U428	Valid for SL 65 AMG and SL 600	2H
U428	Valid for SL 65 AMG and SL 600	19H
W15	Power ground (electronics)	29H
W15	Power ground (electronics)	4E
W24	Ground (roll bar control unit)	2E
W6	Ground (left wheelhouse in luggage compartment)	27E
W6	Ground (left wheelhouse in luggage compartment)	33H
W6	Ground (left wheelhouse in luggage compartment)	53H
W6	Ground (left wheelhouse in luggage compartment)	68E
W6/1	Ground (left taillamp in trunk)	25H
W6/1	Ground (left taillamp in trunk)	41H
W6/1	Ground (left taillamp in trunk)	36H
W6/1	Ground (left taillamp in trunk)	66E
W6/1	Ground (left taillamp in trunk)	39F
W6/1	Ground (left taillamp in trunk)	34F
X111	Tubular frame "open" intermediate connector	65H
X113	Front Vario roof "locked" intermediate connector	66H
X30/15	Driver CAN B voltage distributor connector	59L
X30/16	Front passenger CAN B voltage distributor connector	59L
X30/17	Rear voltage distributor (CAN B) connector	55L
X8/4	Trunk lid separation point	31H
X8/4	Trunk lid separation point	10E
X8/4	Trunk lid separation point	39E
X8/4	Trunk lid separation point	44H
Y55/1	RVC [UVS] valve block	53L

Document number:

pe77.39-p-2101-97kb

Document title:

Wiring diagram for Vario roof control module

Code:

Y55/1y1
Y55/1y2
Y55/1y3
Y55/1y4
Y55/1y5
Y55/1y6
Y57/1
Z6/92

Designation:

Main valve
Roll bar up solenoid valve
Close Vario roof solenoid valve
Open Vario roof solenoid valve
Tubular frame and Vario roof latches solenoid valve
Load assist solenoid valve
RB [URB] deployment solenoid
Trunk lid ground connector sleeve

Position:

49L
50L
51L
50L
52L
52L
1L
38G

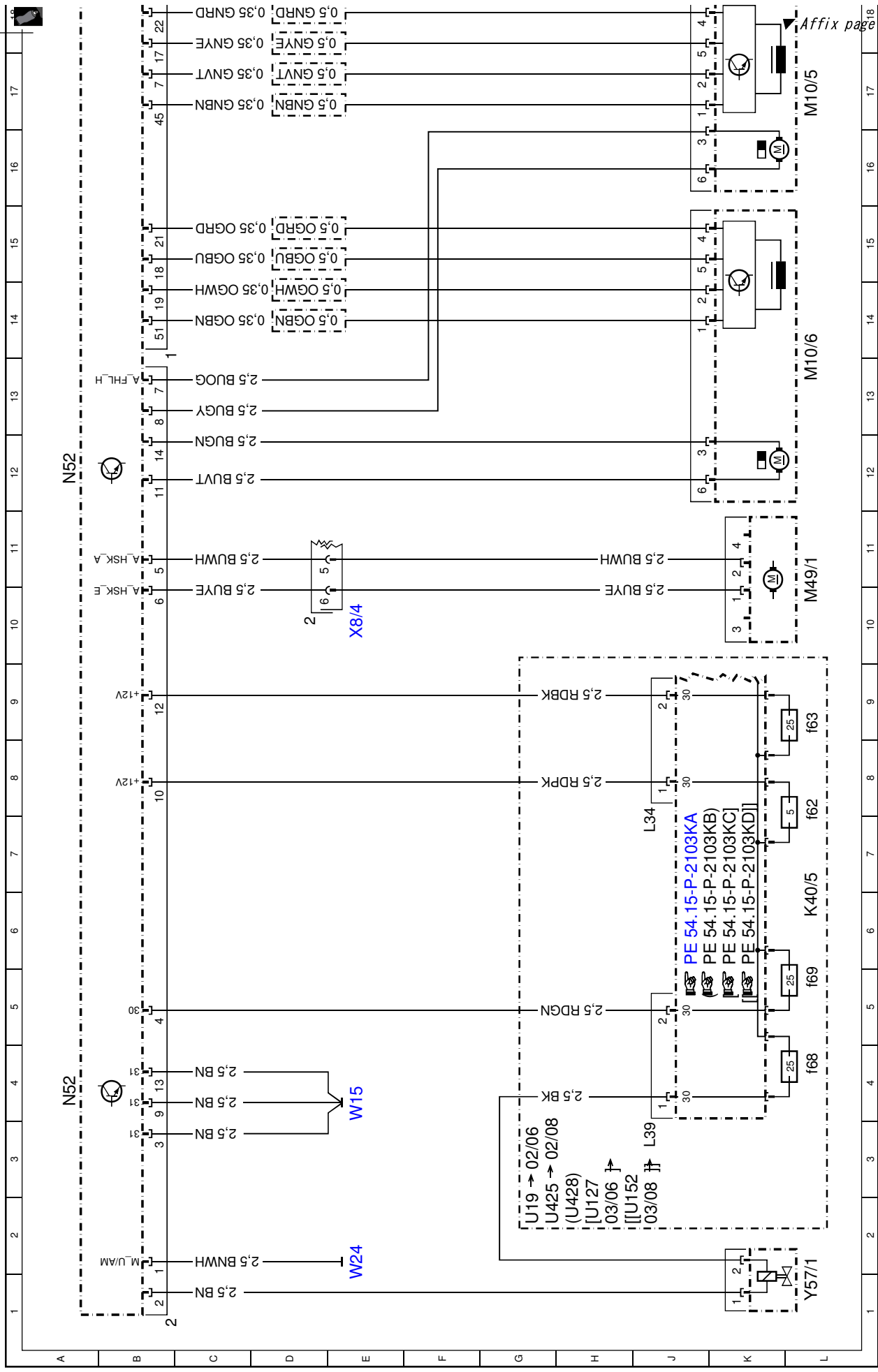

▼ Affix page 2 here ▼

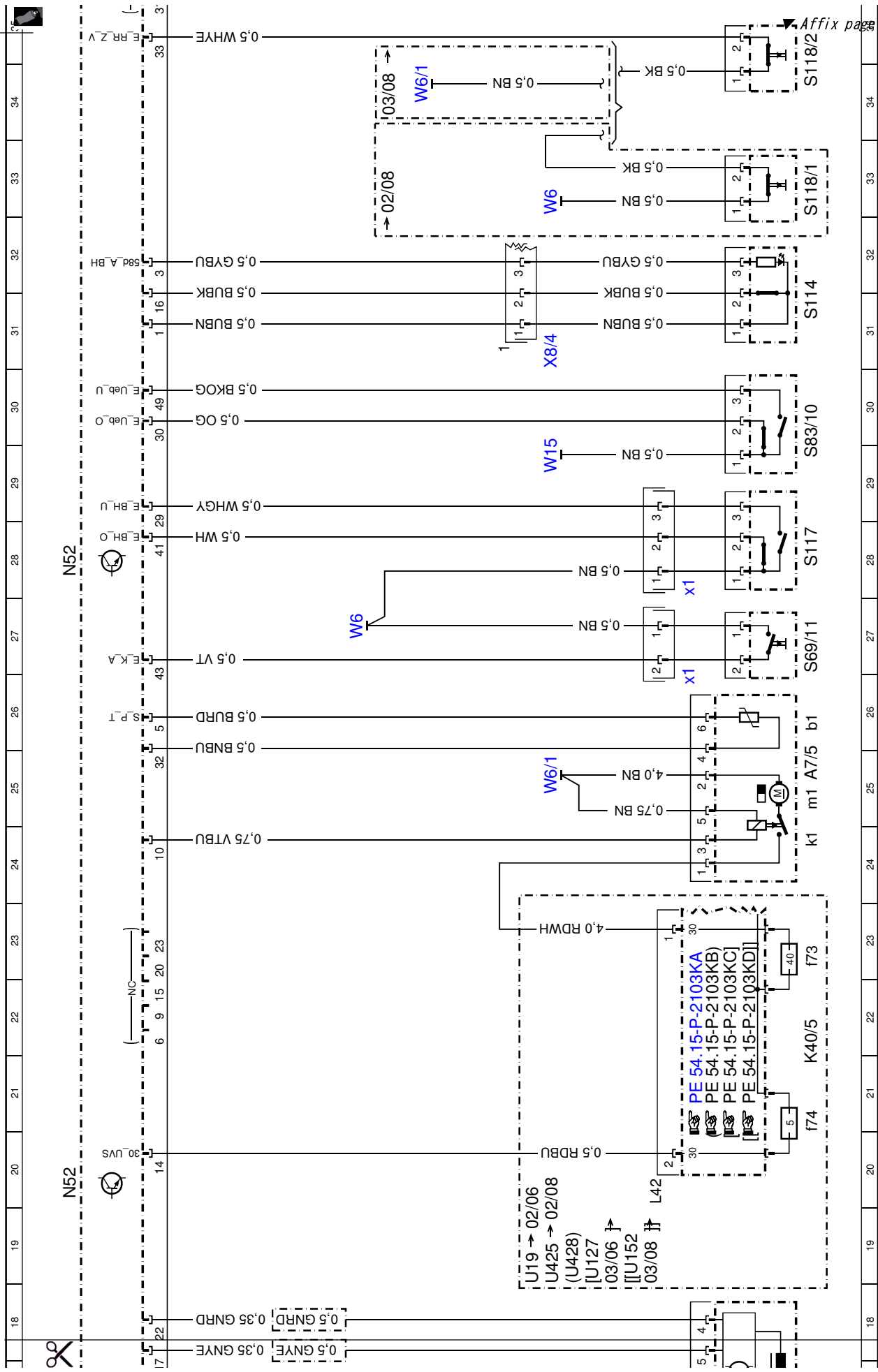

Affix page 3 here

Cut here

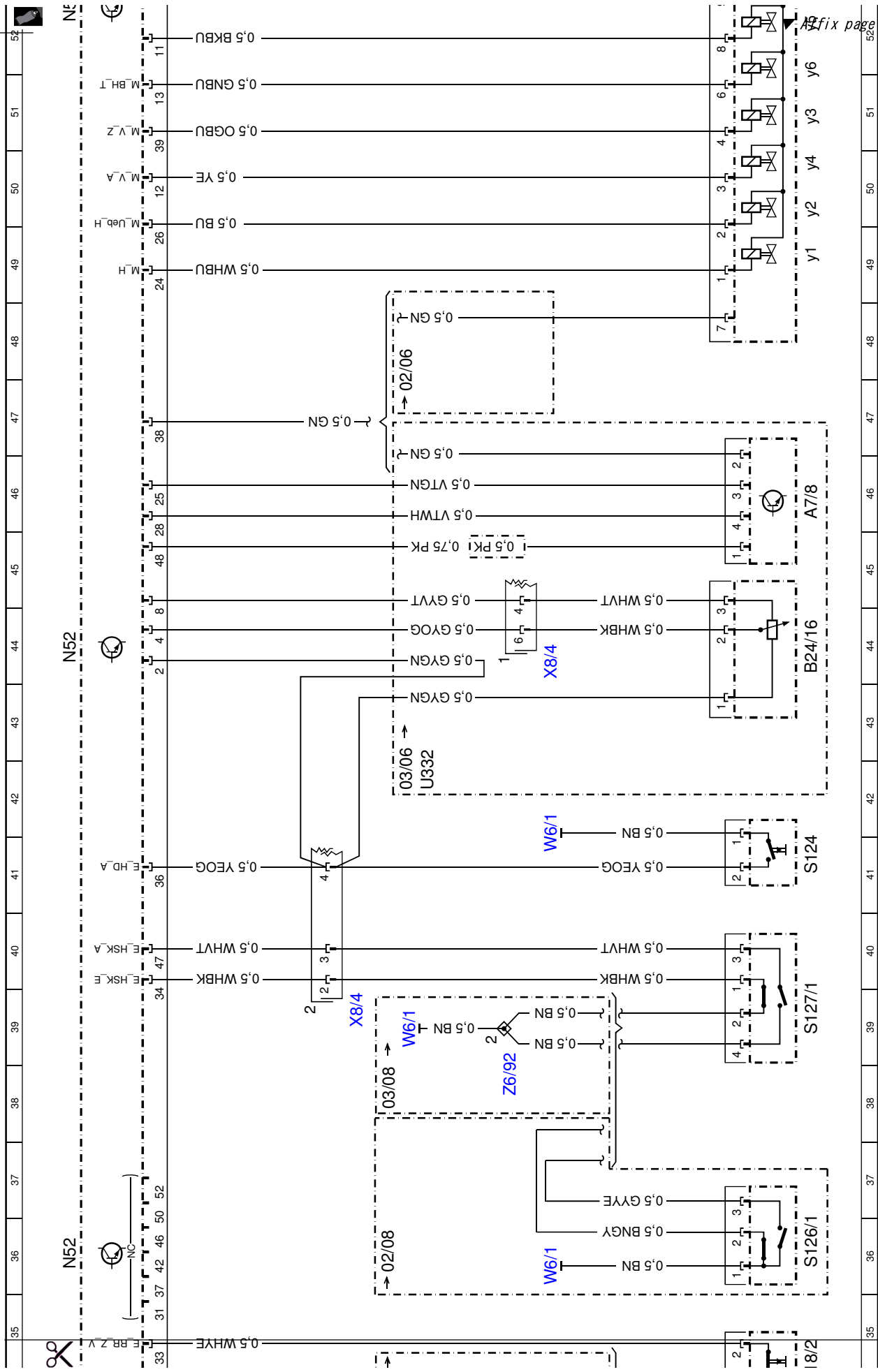

Cut here

Fix page 4 here

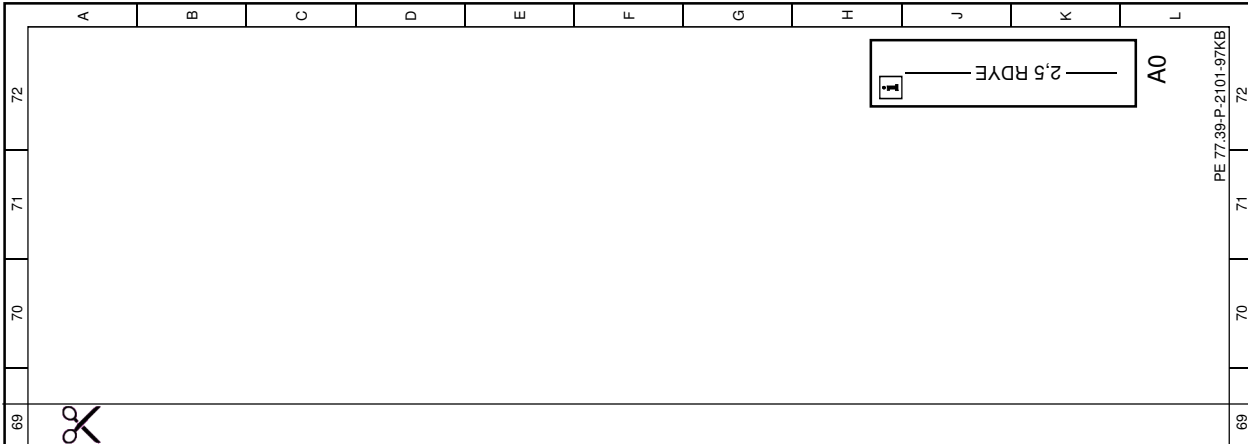

Cut here