

AR35.30-P-0115-01A	Remove/install and secure rear axle shaft twelve-point collar nut		
--------------------	---	--	--

Nm Rear axle shaft

Number	Designation			Model 129	Model 140	Model 170
BA35.30-P-1001-01A	Collar nut, rear axle shaft to rear axle shaft flange	Stage 1	Nm	220	320	220
		Stage 2	Δ°	-	-	-

Nm Rear axle shaft

Number	Designation			Model 202	Model 203	Model 208
BA35.30-P-1001-01A	Collar nut, rear axle shaft to rear axle shaft flange	Stage 1	Nm	220	220	220
		Stage 2	Δ°	-	-	-

Nm Rear axle shaft

Number	Designation			Model 209 except 209.377/477, model 209 without code P98	Model 209.377/477, model 209 with code P98
BA35.30-P-1001-01A	Collar nut, rear axle shaft to rear axle shaft flange	Stage 1	Nm	220	320
		Stage 2	Δ°	-	-

Nm Rear axle shaft

Number	Designation			Model 210.0	Model 210.2/6
BA35.30-P-1001-01A	Collar nut, rear axle shaft to rear axle shaft flange	Stage 1	Nm	220	320
		Stage 2	Δ°	-	-

Nm Rear axle shaft

Number	Designation			Model 211	Model 215
BA35.30-P-1001-01A	Collar nut, rear axle shaft to rear axle shaft flange	Stage 1	Nm	170	320

Stage 2	∠°	45	-
---------	----	----	---

Nm Rear axle shaft

Number	Designation	Model 220		
BA35.30-P-1001-01A	Collar nut, rear axle shaft to rear axle shaft flange	Stage 1	Nm	320
		Stage 2	∠°	-

Nm Rear axle shaft

Number	Designation			Model 230 except 230.479	Model 230.479 without code P99	Model 230.479 with code P99
BA35.30-P-1001-01A	Collar nut, rear axle shaft to rear axle shaft flange	Stage 1	Nm	170	150	380
		Stage 2	∠°	45	45	-

Detaching

- 1 Apply parking brake
- 2 Unscrew twelve-point collar nut (12).

Mount on and secure

i The twelve-point collar nut should be replaced each time it is unscrewed.

- 3 Tighten twelve-point collar nut (12) **Nm**
- 4 Secure twelve-point collar nut (12) with caulker so that no gap remains between the groove and locking collar of the twelve-point collar nut.
 - i** Secure twelve-point collar nut double (arrows).
- 5 Release parking brake.

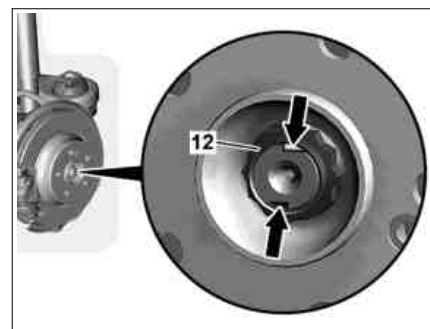

P35.30-2137-01