

MODEL 209 except CODE (581b) Convenience automatic air conditioning

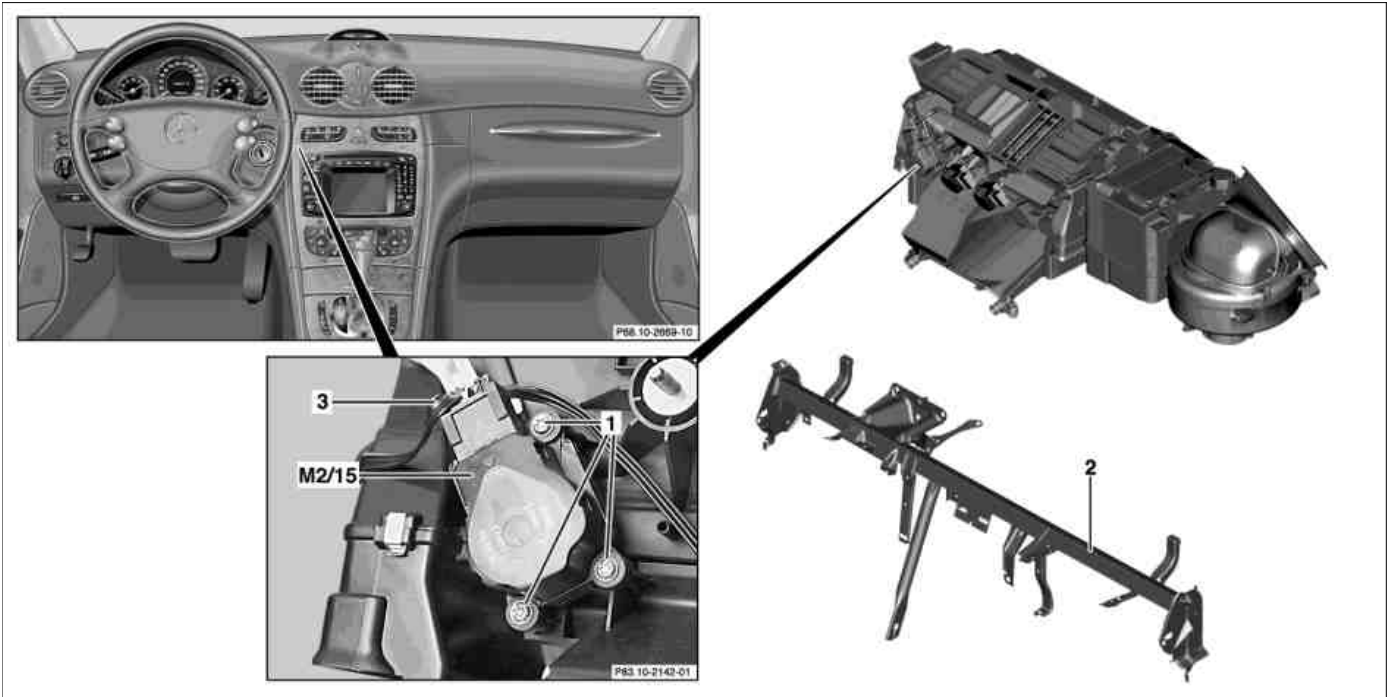

P83.10-2267-09

- 1 Bolts
- 2 Cross member below instrument panel
- 3 Electrical connector
- M2/15 Left and right footwell flaps actuator motor

Modification notes

18.2.04	Disconnect/connect/remove ground lead from battery		
---------	--	--	--

		Remove/Install		
		1 Remove cross member under instrument panel (2)	Model 209.3 Model 209.4	AR68.10-P-1120Q AR68.10-P-1120QA
		2 Remove damping in the area of the left and right footwell flaps actuator motor (M2/15)		
		3 Remove bolts (1)		
		4 Detach left and right footwell flap actuator motor (M2/15)		
		5 Separate electrical connection (3)		
		6 Install in the reverse order		
		7 Connect STAR DIAGNOSIS, normalize left and right footwell flaps actuator motor (M2/15), read out and erase fault memory Connect STAR DIAGNOSIS and read out fault memory	Diagnosis system STAR DIAGNOSIS	AD00.00-P-2000-04A *WH58.30-Z-1048-13A
		8 Perform function check		

Commercially available tools

Number	Designation	
WH58.30-Z-1048-13A	STAR DIAGNOSIS diagnosis system, Compact Passenger Car	6511 1801 00